



Version	Change NO.	Autograph	Date

# 3.5mm-3.5mm ADAPTERS F/F 33GHZ

## A-35F35F-BF

### SPECIFICATIONS

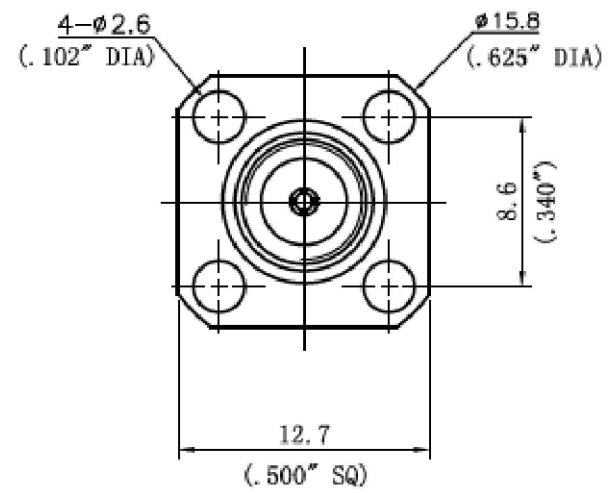
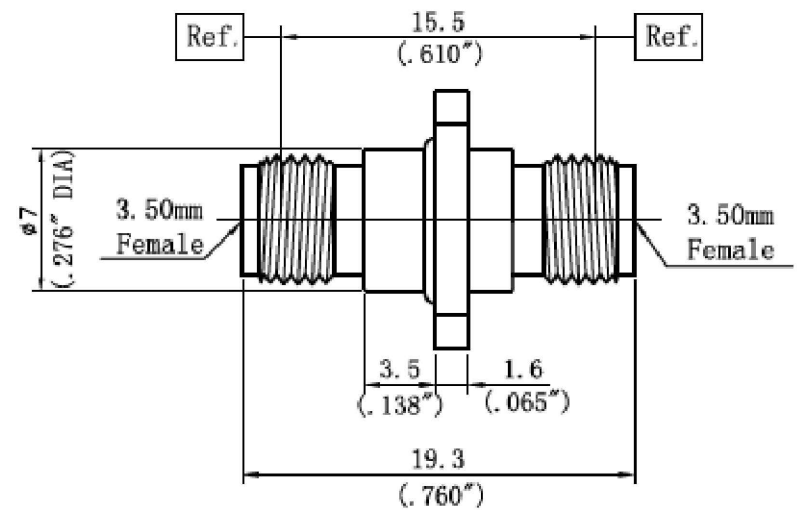

#### ELECTRICAL

VSWR: 1.15:1  
 Frequency: DC-33 GHz  
 Impedance: 50 Ohms

#### MECHANICAL

1000 Cycles Min

#### ENVIRONMENTAL

-55° C -- +125° C  
 Corrosion: MIL-STD 202  
 Vibration: MIL-STD 202

#### MATERIALS

Body: SU304 Polished & Passivated  
 Center Contact : Beryllium Copper Gold Plated  
 Insulators: PEI

Jointly sign  
 Quality department  
 Production department  
 Purchasing Department

Material:	Important size	Key dimensions	Shanghai Juncoax RF Technologies Co., Ltd
Drafting: Yuan.YJ	*	▲	Material number: ZJQ-0085
Check: Ming.WM	Marker phase	Version	Proportion
Standard: Liang.DH	P	A/0	Property
Approval: Colin.tsai	Unit	mm	Model: A-35F35F-BF
ALL (1) page No. (1) page			