

Version	Change NO.	Autograph	Date

# 3.5mm-3.5mm ADAPTERS F/F 33GHZ

## A-35F35F-BH

### SPECIFICATIONS

#### ELECTRICAL

VSWR: 1.15:1

Frequency: DC-33 GHz

Impedance: 50 Ohms

#### MECHANICAL

1000 Cycles Min

#### ENVIRONMENTAL

-55° C -- +125° C

Corrosion: MIL-STD 202

Vibration: MIL-STD 202

#### MATERIALS

Body: SU304 Polished & Passivated

Center Contact : Beryllium Copper Gold Plated

Insulators: PEI

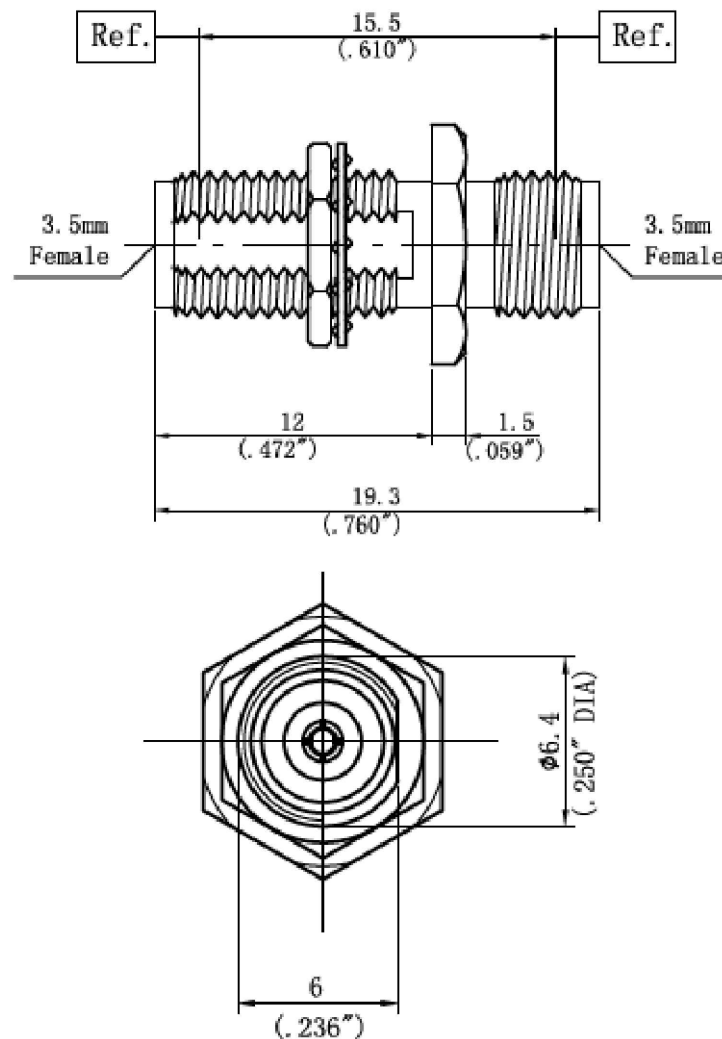

Jointly sign

Quality department
Production department
Purchasing Department

Material:	Important size	Key dimensions	Shanghai Juncoax RF Technologies Co., Ltd
Drafting: Yuan.YJ	*	▲	Material number: ZJQ-0087
Check: Ming.WM	Marker phase	Version	Proportion
Standard: Liang.DH	P	A/0	Property
Approval: Colin.tsai			Unit
			mm
	ALL (1) page	No. (1) page	