

Version	Change NO.	Autograph	Date



# BNC-SMA ADAPTERS M/M 8GHZ

## A-BMSM

### SPECIFICATIONS

#### ELECTRICAL

**VSWR: 1.15:1**  
**Frequency: DC-8 GHz**  
**Impedance: 50 Ohms**

#### MECHANICAL

**1000 Cycles Min**

#### ENVIRONMENTAL

**-55° C -- +125° C**  
**Corrosion: MIL-STD 202**  
**Vibration: MIL-STD 202**

#### MATERIALS

**Body: SU304 Polished & Passivated**  
**Center Contact : Beryllium Copper Gold Plated**  
**Insulators: PEI&PTFE**  
**Coupling Nut : Brass Nickel Plated**

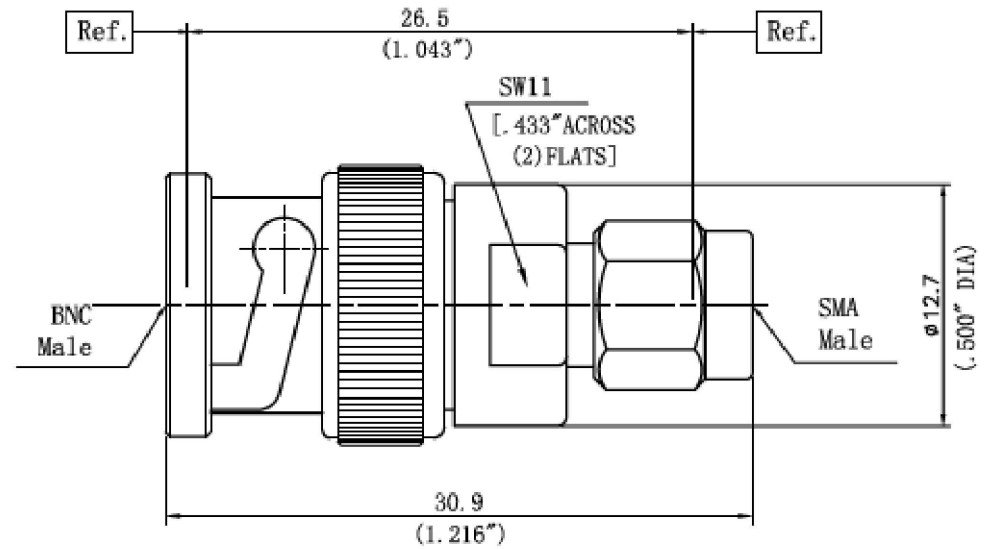

Jointly sign  
 Quality department  
 Production department  
 Purchasing Department

Material:	Important size	Key dimensions			Shanghai Juncoax RF Technologies Co., Ltd	
Drafting: Yuan.YJ	*	▲			Material number: ZJQ-0111	
Check: Ming.WM	Marker phase	Version	Proportion	Property	Unit	Model: A-BMSM
Standard: Liang.DH	P	A/0	2:1		mm	
Approval: Colin.tsai	ALL (1) page No. (1) page					

