

Version	Change NO.	Autograph	Date



# 7/16 -7/16 ADAPTERS M/M 6GHZ

## A-DMDM

### SPECIFICATIONS

#### ELECTRICAL

VSWR: 1.15:1 (Max)  
 Frequency: DC-6 GHz  
 Impedance: 50 Ohms

#### MECHANICAL

1000 Cycles Min

#### ENVIRONMENTAL

-55° C -- +125° C  
 Corrosion: MIL-STD 202  
 Vibration: MIL-STD 202

#### MATERIALS

Body: Brass Trimetal Plated  
 Center Contact : Beryllium Copper Silver Plated  
 Insulators: PEI

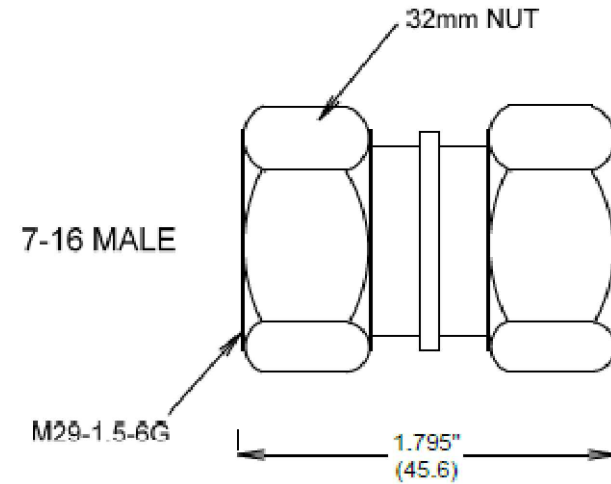

Jointly sign  
 Quality department  
 Production department  
 Purchasing Department

Material:	Important size	Key dimensions	Shanghai Juncoax RF Technoloies Co.,Ltd
Drafting: Yuan.YJ	*	▲	Material number:ZJQ-0099
Check: Ming.WM	Marker phase	Version	Proportion
Standard: Liang.DH	P	A/0	Property
Approval: Colin.tsai			Unit
			mm
			Model:A-DMDM
			ALL (1) page No. (1) page

