

| | | | |
|---------|------------|-----------|------|
| Version | Change NO. | Autograph | Date |
| | | | |



7/16 -N ADAPTERS M/M 8GHZ

A-DMNM

SPECIFICATIONS

ELECTRICAL

VSWR: DC-3GHz:1.10:1(Max)
 DC-8GHz:1.15:1(Max)
 Frequency: DC-8 GHz
 Impedance: 50 Ohms

MECHANICAL

1000 Cycles Min

ENVIRONMENTAL

-55° C -- +125° C
 Corrosion: MIL-STD 202
 Vibration: MIL-STD 202

MATERIALS

Body: Brass Trimetal Plated
 Center Contact : Beryllium Copper Silver Plated
 Insulators: PEI

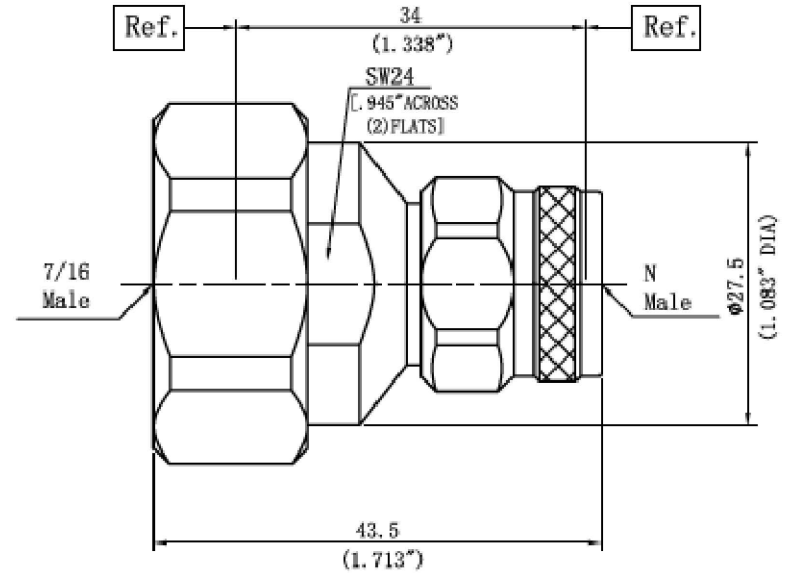

Jointly sign
 Quality department
 Production department
 Purchasing Department

| | | | |
|----------------------|---------------------------|----------------|---|
| Material: | Important size | Key dimensions | Shanghai Juncoax RF Technoloies Co.,Ltd |
| Drafting: Yuan.YJ | * | ▲ | Material number:ZJQ-0153 |
| Check: Ming.WM | Marker phase | Version | Proportion |
| Standard: Liang.DH | P | A/0 | Property |
| Approval: Colin.tsai | | | Unit |
| | | | mm |
| | ALL (1) page No. (1) page | | |