

|         |            |           |      |
|---------|------------|-----------|------|
| Version | Change NO. | Autograph | Date |
|         |            |           |      |



# 2.92mm ADAPTERS F/M 40GHZ

## A-29F29M

### SPECIFICATIONS

#### ELECTRICAL

VSWR: 1.15:1  
 Frequency: DC-40 GHz  
 Impedance: 50 Ohms

#### MECHANICAL

1000 Cycles Min

#### ENVIRONMENTAL

-55° C -- +125° C  
 Corrosion: MIL-STD 202  
 Vibration: MIL-STD 202

#### MATERIALS

Body: SU304 Polished & Passivated  
 Center Contact : Beryllium Copper Gold Plated  
 Insulators: PEI

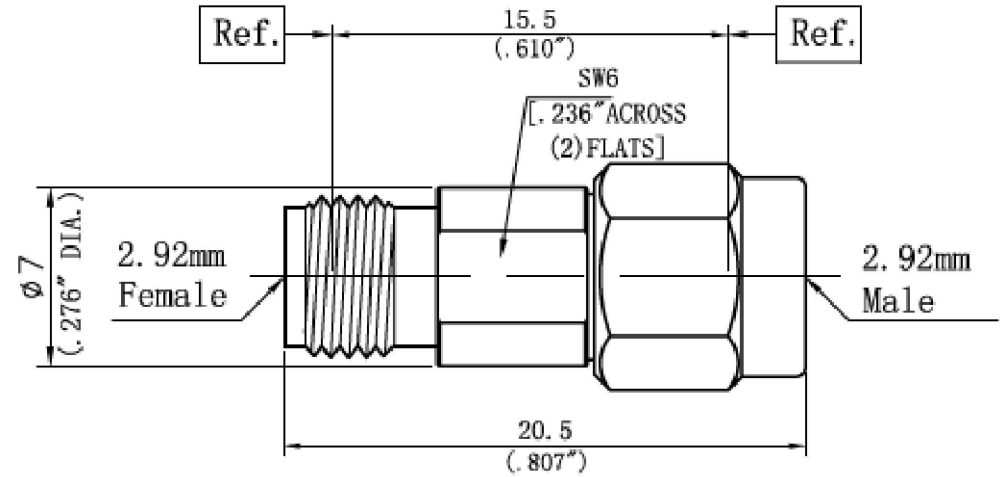

|                       |
|-----------------------|
| Jointly sign          |
| Quality department    |
|                       |
| Production department |
|                       |
| Purchasing Department |
|                       |
|                       |

|                           |                |                |   |
|---------------------------|----------------|----------------|---|
| Material:                 | Important size | Key dimensions | Shanghai Juncoax RF Technologies Co., Ltd |
| Drafting: Yuan.YJ         | *              | ▲              | Material number: ZJQ-0060                 |
| Check: Ming.WM            | Marker phase   | Version        | Proportion                                |
| Standard: Liang.DH        | P              | A/0            | Property                                  |
| Approval: Colin.tsai      | Unit           | mm             | Model: A-29F29M                           |
| ALL (1) page No. (1) page |                |                |   |