

Version	Change NO.	Autograph	Date



# QMA-N ADAPTERS P/F 6GHZ

## A-QPNF

### SPECIFICATIONS

#### ELECTRICAL

VSWR: 1.20:1  
 Frequency: DC-6 GHz  
 Impedance: 50 Ohms

#### MECHANICAL

1000 Cycles Min

#### ENVIRONMENTAL

-55° C -- +125° C  
 Corrosion: MIL-STD 202  
 Vibration: MIL-STD 202

#### MATERIALS

Body: SU304 Polished & Passivated  
 Center Contact : Beryllium Copper Gold Plated  
 Insulators: PTFE&PEI

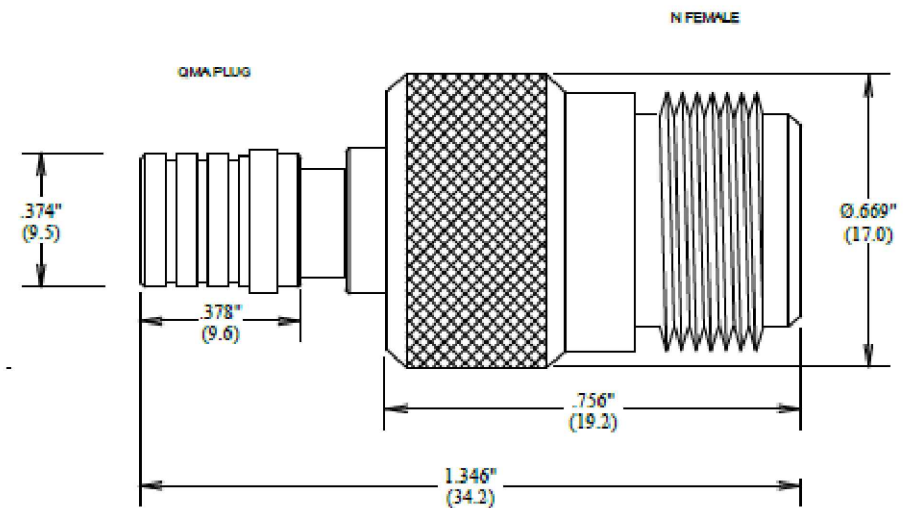

Jointly sign

Quality department
Production department
Purchasing Department

Material:	Important size	Key dimensions	Shanghai Juncoax RF Technologies Co., Ltd
Drafting: Yuan.YJ	*	▲	Material number: ZJQ-0189
Check: Ming.WM	Marker phase	Version	Proportion
Standard: Liang.DH	P	A/0	2:1
Approval: Colin.tsai	ALL (1) page No. (1) page		mm

