

Version	Change NO.	Autograph	Date



# SMA - N ADAPTERS F/M 18GHZ

## A-SFNM

### SPECIFICATIONS

#### ELECTRICAL

VSWR: 1.15:1  
 Frequency: DC-18 GHz  
 Impedance: 50 Ohms

#### MECHANICAL

1000 Cycles Min

#### ENVIRONMENTAL

-55° C -- +125° C  
 Corrosion: MIL-STD 202  
 Vibration: MIL-STD 202

#### MATERIALS

Body: SU304 Polished & Passivated  
 Center Contact : Beryllium Copper Gold Plated  
 Insulators: PTFE&PEI

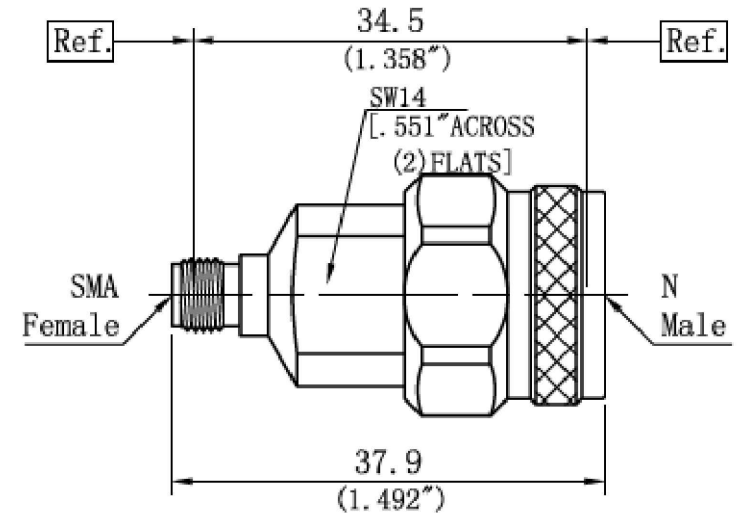

Jointly sign

Quality department
Production department
Purchasing Department

Material:	Important size	Key dimensions	Shanghai Juncoax RF Technoloies Co.,Ltd
Drafting: Yuan.YJ	*	▲	Material number:ZJQ-0171
Check: Ming.WM	Marker phase	Version	Proportion
Standard: Liang.DH	P	A/0	Property
Approval: Colin.tsai			Unit
ALL (1) page No. (1) page			Model:A-SFNM