

Version	Change NO.	Autograph	Date



SMA-QMA ADAPTERS J/P 6GHZ

A-SJQP

SPECIFICATIONS

ELECTRICAL

VSWR: 1.15:1
 Frequency: DC-6 GHz
 Impedance: 50 Ohms

MECHANICAL

1000 Cycles Min

ENVIRONMENTAL

-55° C -- +125° C
 Corrosion: MIL-STD 202
 Vibration: MIL-STD 202

MATERIALS

Body: SU304 Polished & Passivated
 Center Contact : Beryllium Copper Gold Plated
 Insulators: PTFE&PEI

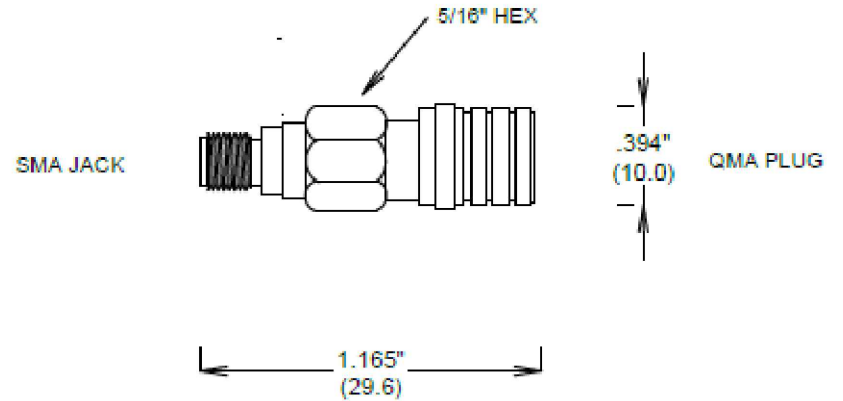

Jointly sign
 Quality department
 Production department
 Purchasing Department

Material:	Important size	Key dimensions	Shanghai Juncoax RF Technologies Co., Ltd
Drafting: Yuan.YJ	*	▲	Material number: ZJQ-0192
Check: Ming.WM	Marker phase	Version	Proportion
Standard: Liang.DH	P	A/O	2:1
Approval: Colin.tsai	ALL (1) page No. (1) page		mm